

THE JUNIPER SaM146 SHORT ENGINE WASH PROBES

JMP/SaM146/D/6797

(Supplied as set of two)

Information sheet

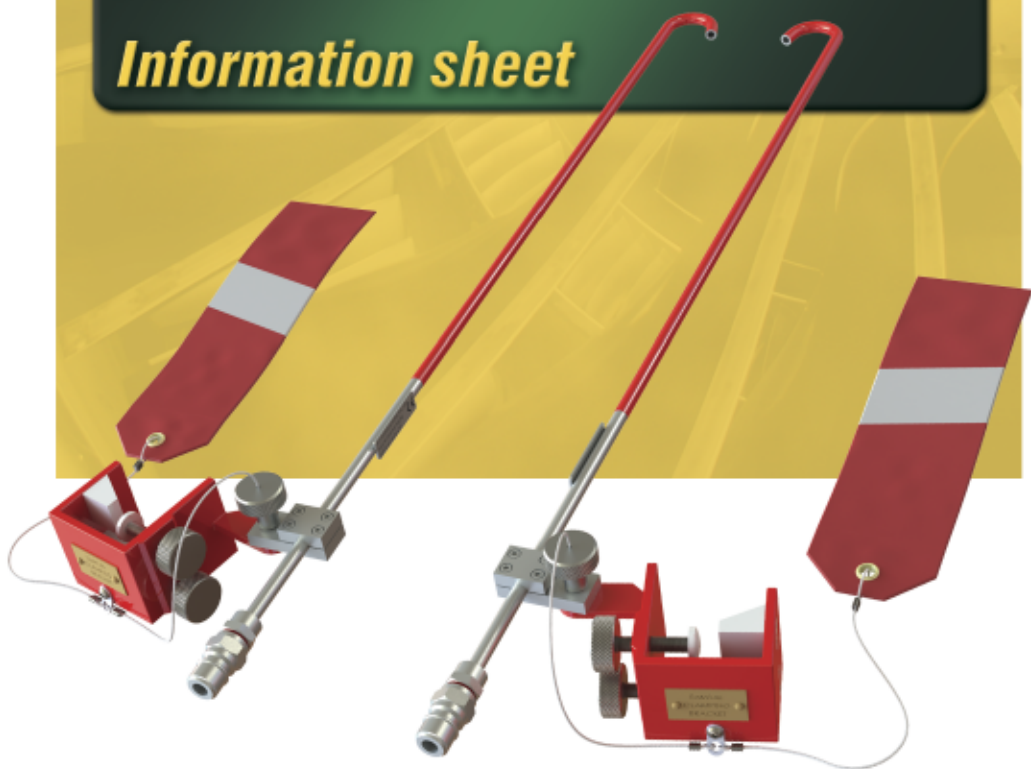

AIRCRAFT SERVICE EQUIPMENT



CLAMPING BRACKET: Main parts identified.

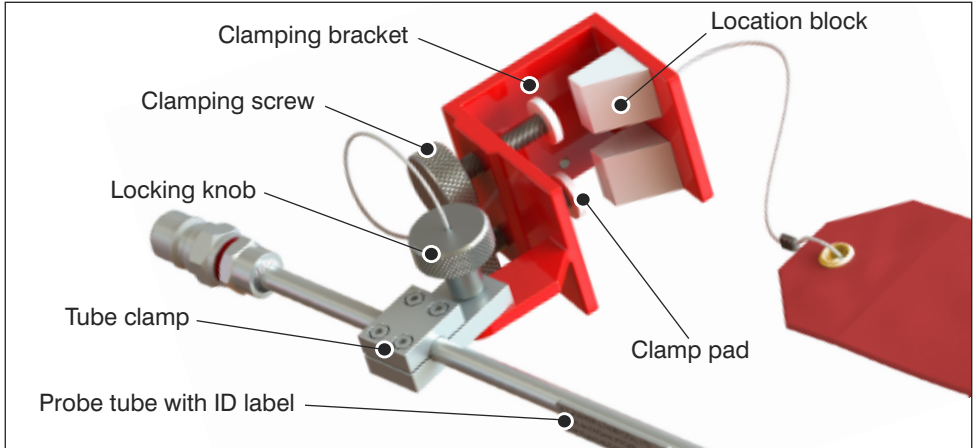

PROBE ASSEMBLY: Main points and connection to twin hose assembly.

Note: The probes shown here are for illustrative purposes only and are not necessarily the actual probes featured.

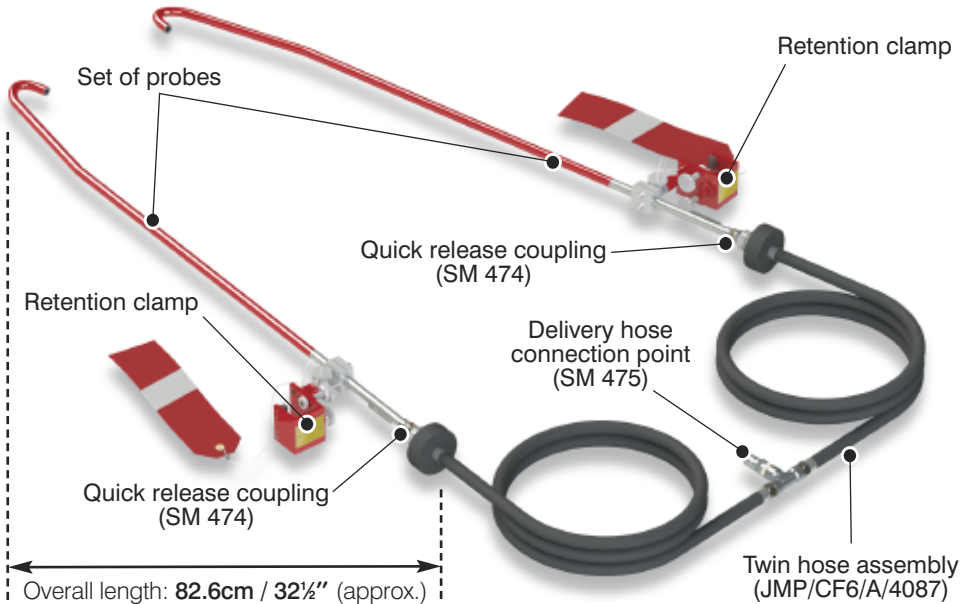

AIRCRAFT SERVICE EQUIPMENT

A.T.Juniper (Liverpool) Limited.
Marshall Works,
5-17 Bleasdale Road, Allerton,
Liverpool L18 5JB

Tel: +44(0)151 733 1553
Fax: +44(0)151 734 3166

Also at:
Ash House, Prenton Way,
North Cheshire Trading Estate,
Prenton, Wirral CH43 3DU

Email: gse@juniper-liverpool.com
Web: www.juniper-liverpool.com

Contractors to
H.M. Government
Departments

Registered with:
ISO 9001:2015